

Valve Automation Solutions

- A Series
- AT Series
- Fail-Safe Systems
- SIL-3 Capable
- Pneumatic & Hydraulic Controls
- AS Series
- A²A Booster
- Electrical Controls
- CE/PED Certified
- Customized Solutions



Valve Actuation

Cowan has built an international reputation on the quality of our products and their performance for the world's most challenging environments.



A Series
Pneumatic Valve Actuators
Double-Acting
Bore size: 4" to 42"
Piston rod diameter: 1" to 5 1/2"
Thrust: Up to 250,000 lbs
Low Temp: -54°C to 90°C
High Temp: -10°C to 200°C



AS Series
Spring-Return Pneumatic Valve Actuators
Fail-close or fail-open
Valve Size: 2" to 10"
Thrust: Up to 13,700 lbs
Larger sizes available
3 week quick ship option
Low Temp: -54°C to 90°C
High Temp: -10°C to 200°C



AT Series
Pneumatic Modulating Valve Actuators with Integral Position Transducer
Double-Acting or Spring-Return
Bore Size: 5" to 42"
Piston rod diameter: 1" to 5 1/2"
Thrust: Up to 250,000 lbs
Low Temp: -40°C to 90°C
Stand Temp: -20°C to 90°C



A²A Booster: 250 psi
Dual-stage High-output Pneumatic Booster
Ratios 2:1, 3:1 and 4:1
125 psi max inlet pressure
250 psi max outlet pressure
Low Temp: -48°C to 60°C



ML Series: 3,000 psi
Hydraulic Valve Actuators
Double-Acting or Spring-Return
Bore Size: 1 1/2" to 20"
Piston Rod Diameter: 5/8" to 10"
Thrust: Up to 1.5 Million lbs
Low Temp: -54°C to 60°C
High Temp: -29°C to 205°C



P & V Series
High Pressure Air & Direct Gas Actuators
Bore Size: 6" to 24"
Strokes up to 36"
Thrust: Up to 750,000 lbs
NACE available for Sour direct gas

Mounting & Control Solutions

We offer a wide range of options to facilitate both the valve adaption and the valve operation process.

Mounting Kits: ISO, MSS, & Customized Patterns Available

Cowan valve mounting kits can be designed for any linear valve. Mounting kits available in steel and stainless steel construction.

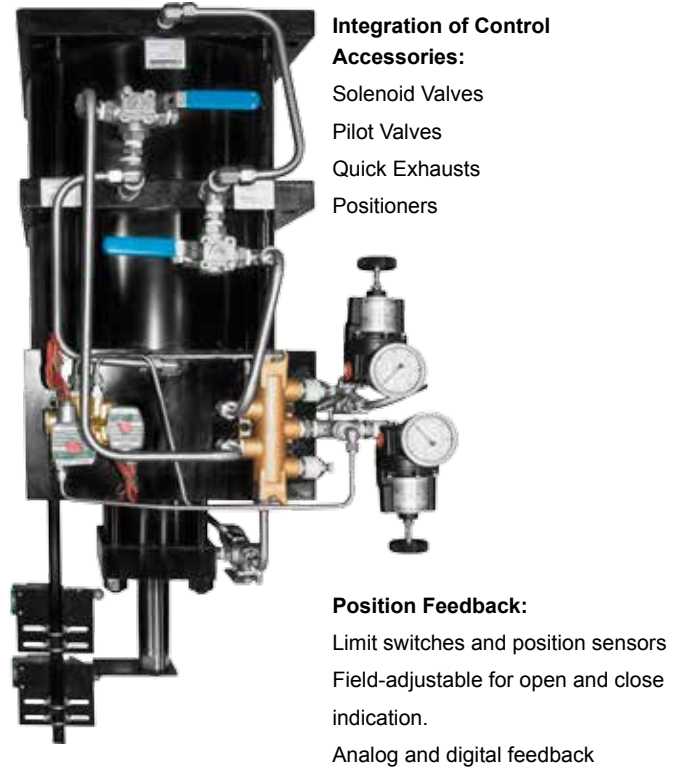
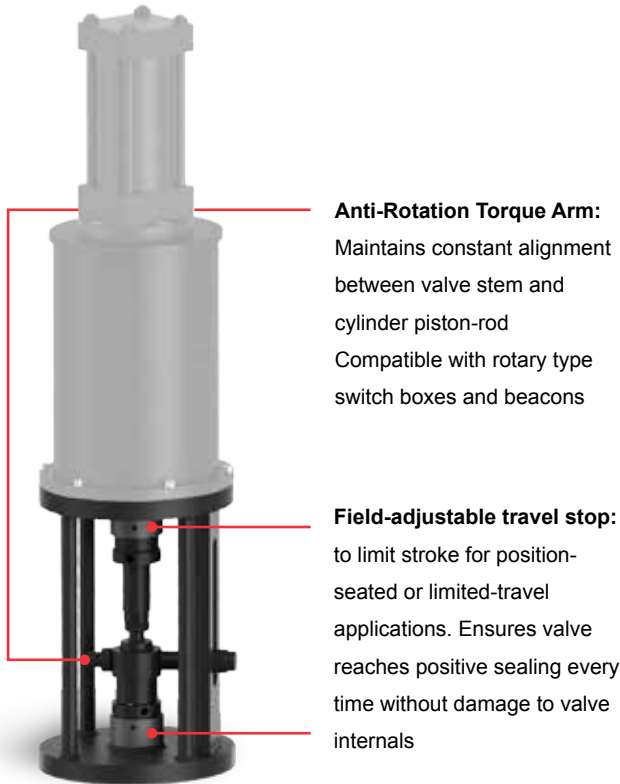

Manual Overrides

Manual override options are available.

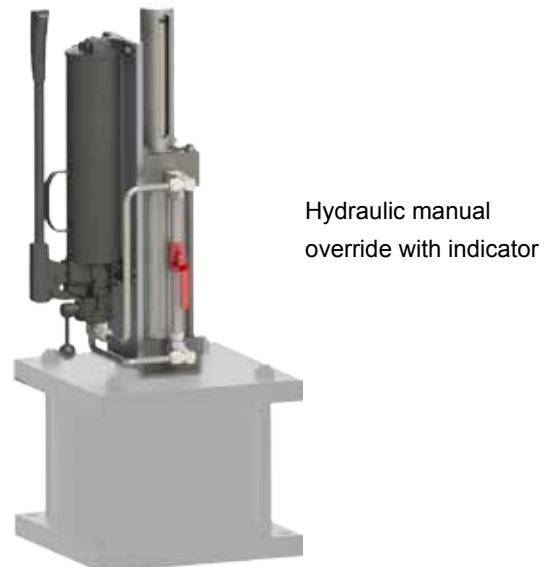



Digital HMI



Electrical / Pneumatic



Pneumatic

Fail-Safe Systems and Control Panels

We offer a wide range of valve automation control options including control panels, plc panels and fail-safe systems.

Do more with less

A²A Systems are significantly smaller and lighter than a conventional air tank system. Below is an example of how air-assisted fail-safe systems which use Cowan's A²A pneumatic booster provide a more economical solution than a conventional air tank fail-safe system

Example:

Conventional System

- 785 lbs
- 400 gallon tank
- 30"x30" footprint
- 20" Bore pneumatic valve actuator



upto **85%** Smaller

upto **45%** Lighter

The A²A System

- 430 lbs
- 60 gallon tank
- 20"x20" Footprint
- 16" Bore pneumatic valve actuator

cowan dynamics

Cowan Dynamics supplies a diverse set of products and services to the Power, Oil & Gas, Mining and Process Industries. Our automation division specializes in the design and manufacturing of a broad range of automated industrial equipment. Based on years of valuable experience, we pride ourselves on the quality of our engineering, manufacturing and problem solving capabilities

Related materials

Visit our website to download or request a printed catalogue.



Solutions Include:

Valve Actuators

Fail-Safe Systems

Digital Process Control Panels

Pneumatic Process Control Panels

**For sales and technical information,
Contact us at:**

Head Office/Factory:

6194 Notre Dame West
Montreal, Quebec H4C 1V4
TOLL-FREE: 855-341-3415

Sales Office:

211 Watline Ave, Unit 205
Mississauga, Ontario L4Z 1P3
T: 905-829-2910
TOLL-FREE: 855-341-3415
info@cowandynamics.com

f /cowandynamics

in /company/cowan-dynamics

You Tube /cowandynamics

g+ /+cowandynamics

